



## Washer, Electrical Equipment Bond

# WEEB

Patent Pending

## INSTALLATION INSTRUCTIONS *For Solar World Groundmount only*

Please read carefully before installing.

Wiley Electronics recommends that the sufficient details of the installation be submitted to the AHJ for approval before any work is started.

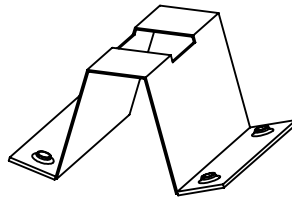

WEEB-DPF

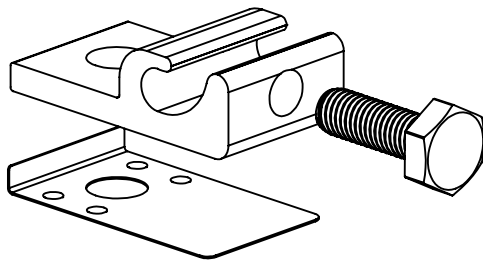

WEEBLug-8.0

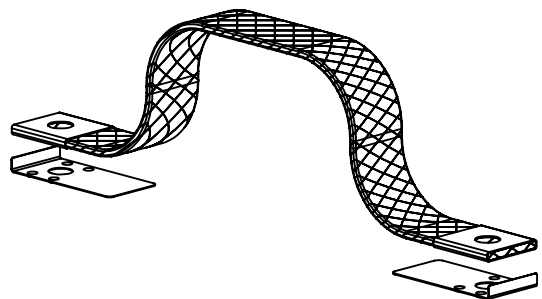

WEEB Bonding Jumper-8.0

Products are tested to UL 467, CAN/CSA-C22.2 No. 41  
US/Canadian standards for safety grounding and bonding equipment



# WEEB COMPATIBILITY

The WEEB family of products can be used to bond anodized aluminum, galvanized steel, steel and other electrically conductive metal structures. All installations shall be in accordance with NEC requirements in the USA and with CSA C22.1 in Canada. The WEEBs are for use with modules that have a maximum series fuse rating of less than 25A.

## Standard Top Down Clamps

The WEEBs used for bonding the PV modules to the mounting rails are compatible with various cross-sections of module frames. The following are examples of module frames that are compatible. Notice that the WEEB teeth are positioned completely under the edge of the module frame.

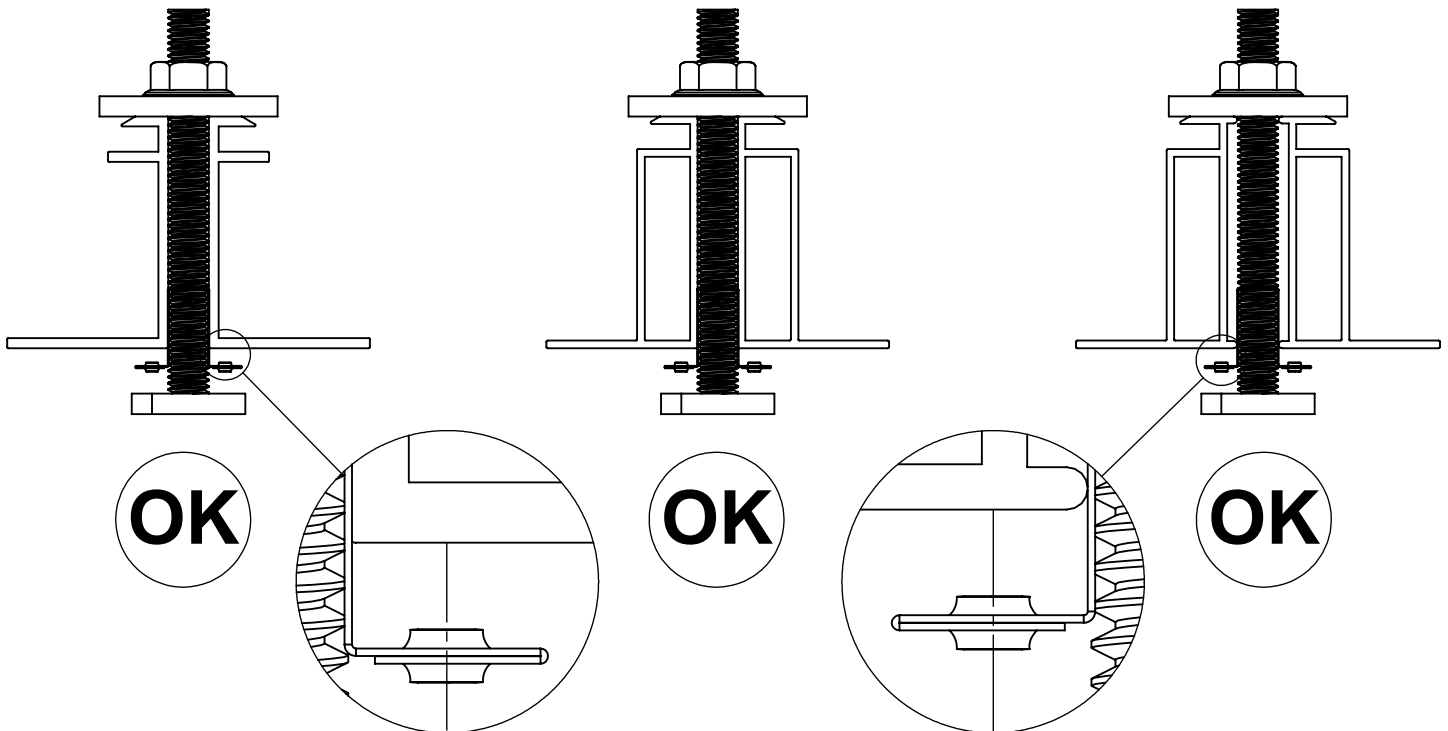

The following is an example of a module frame that is incompatible with the WEEB. The module frame will not contact the flexible leg of the WEEB-DPF. If the module doesn't sit against the leg, the WEEB teeth will not sit in the proper location.

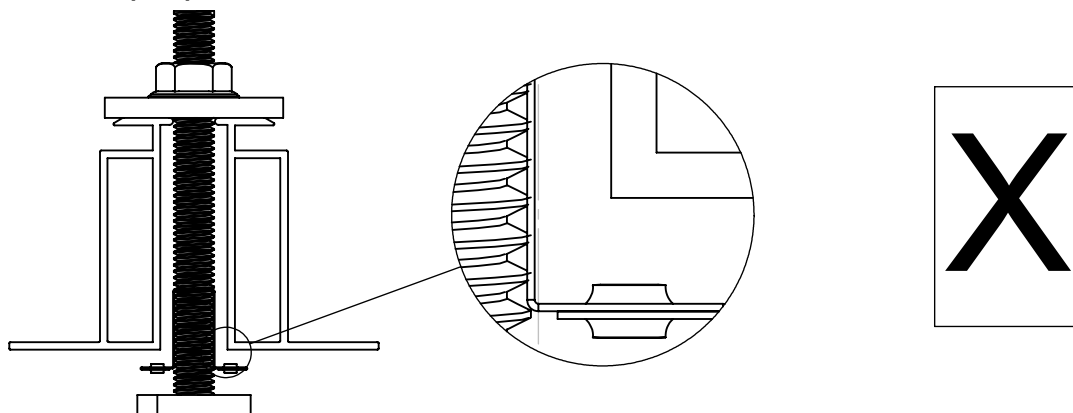

# WEEB COMPATIBILITY

Module frames like those shown here may have a ridge or lip on the bottom edge of the frame that would prevent the WEEB teeth from fully embedding.

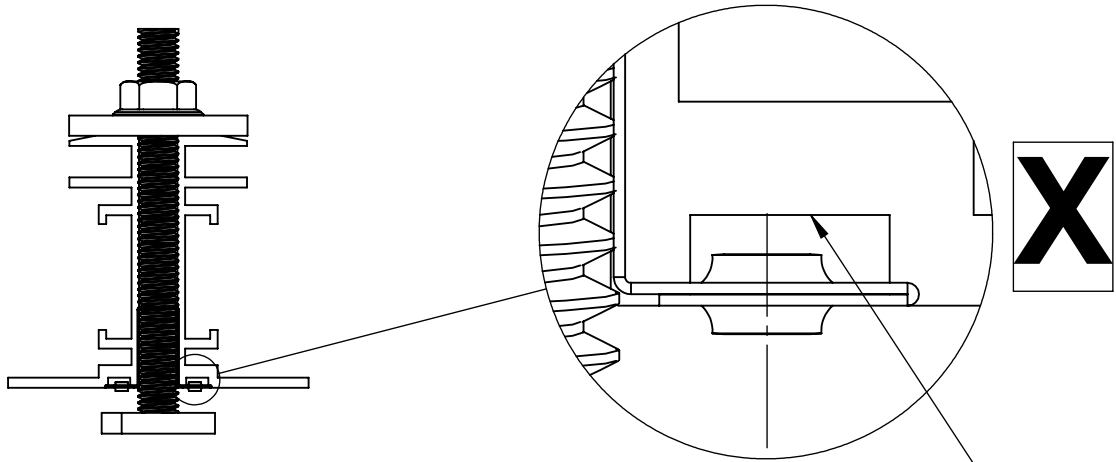

Shown here is an example of a groove that will prevent the WEEB teeth from properly penetrating the module frame. This type of frame is not compatible with the WEEB.

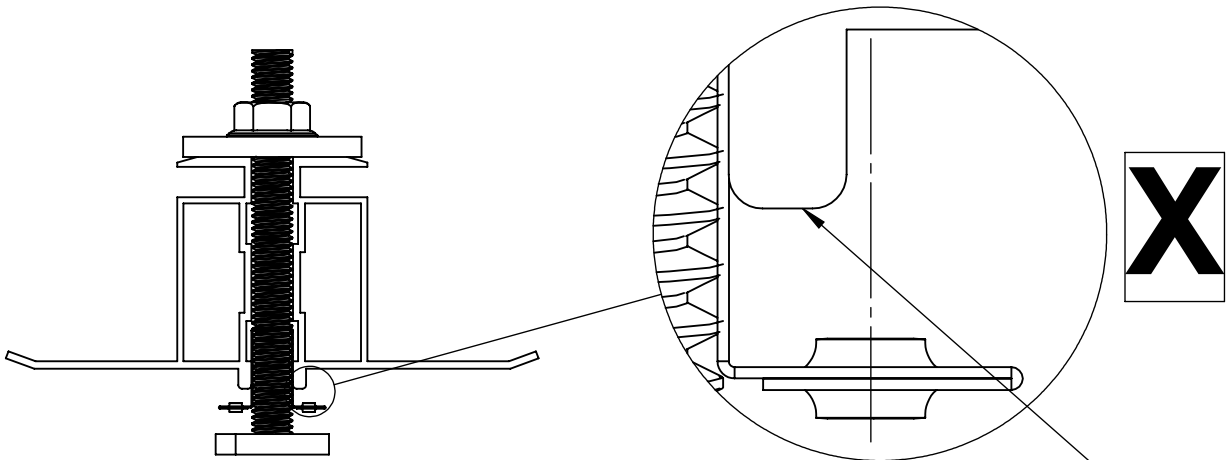

Shown here is an example of a lip that will prevent the WEEB teeth from properly penetrating the module frame. This type of frame is not compatible with the WEEB.

## Important Note:

**Inspect each module frame used with a WEEB to ensure that the bottom mounting face of the frame is flat, and that there are no hinderances to embedding WEEB teeth. Do not use a module with a frame that prevents the WEEB teeth from embedding fully.**

# WEEB-DPF on Boxed Module Frames

Certain module frames do not have enough structural strength to withstand the force required to embed a WEEB. These frames will deform and therefore not allow sufficient penetration of the WEEB teeth. The general requirements for minimum module frame thickness of "boxed" type module frames are illustrated below.

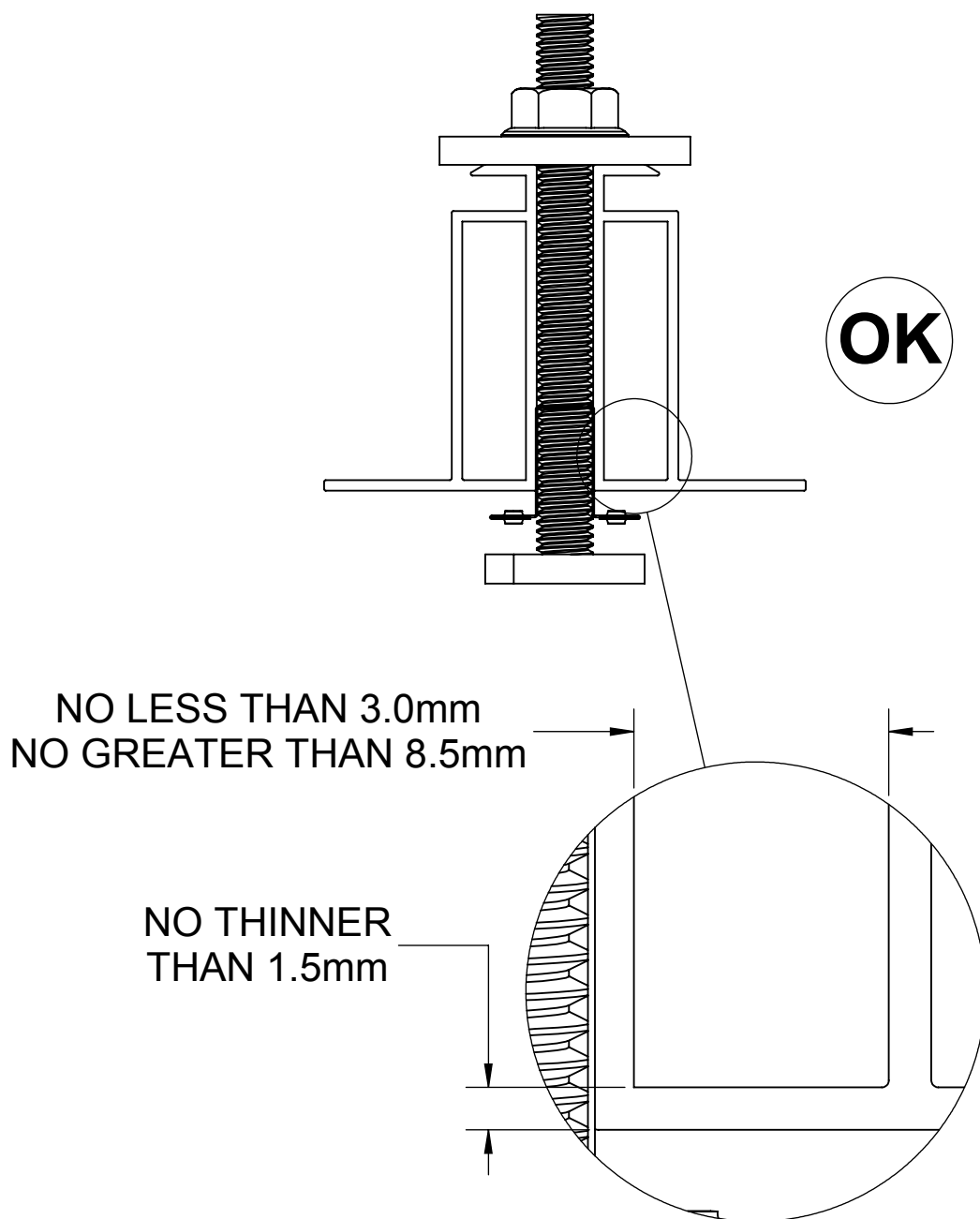

# SYSTEM OVERVIEW

Use one WEEBLug-8.0 assembly per rail to connect system to equipment ground conductor.

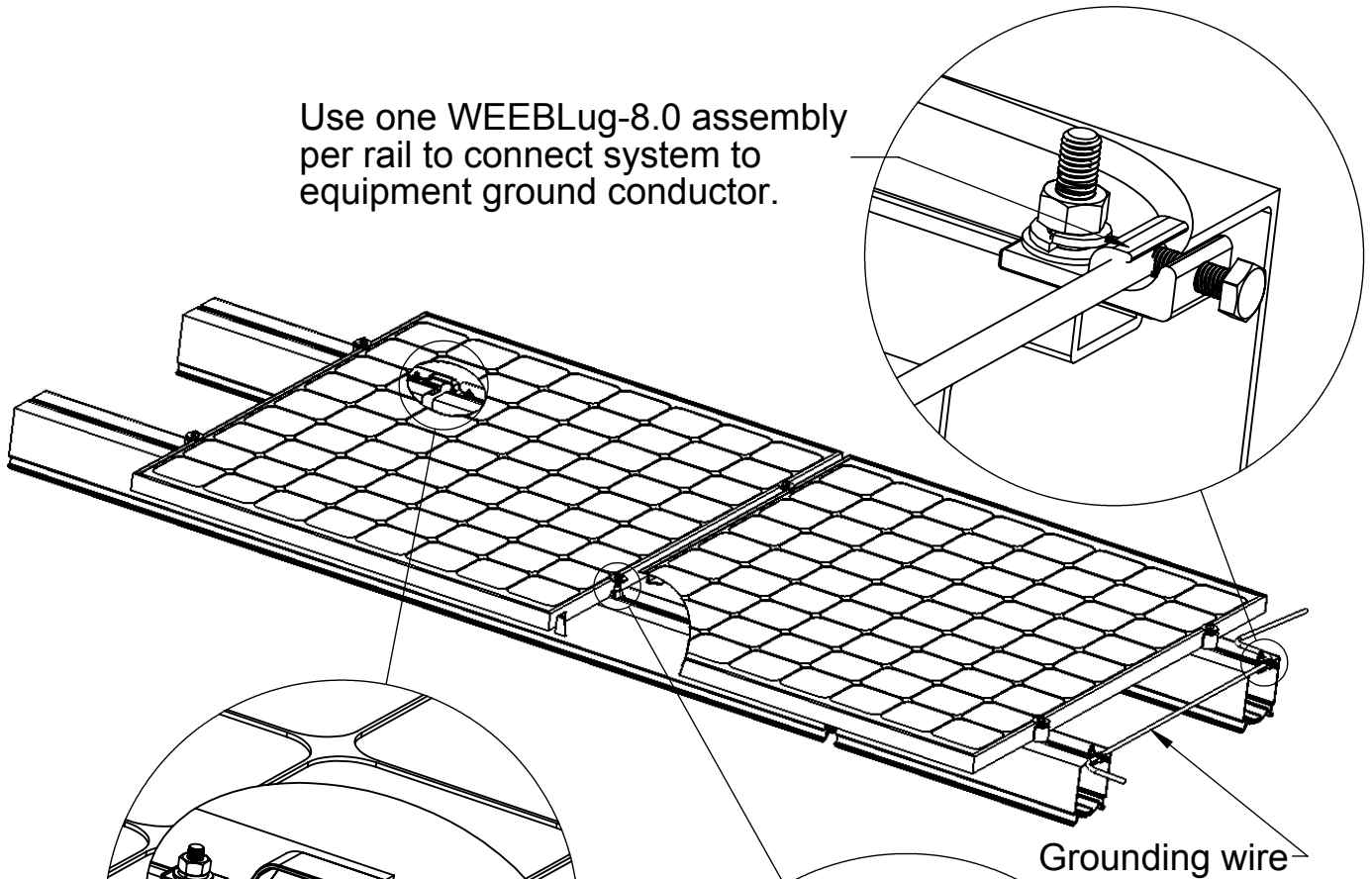

Grounding wire

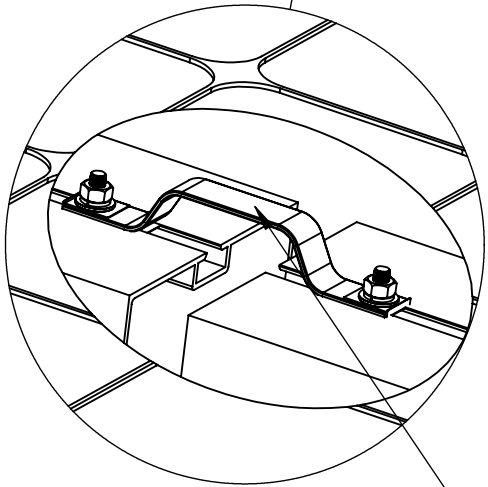

Use WEEB Bonding Jumper to electrically connect mechanically spliced rails.

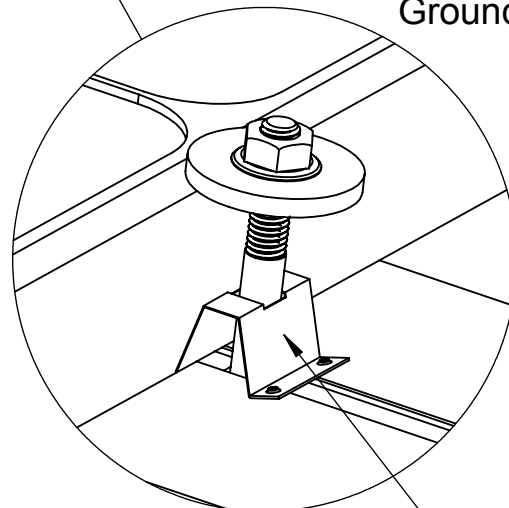

Use WEEB-DPF to bond solar modules to module mounting rail.

## Important notes

1. Use general purpose anti-seize compound on fastener threads when installing WEEBs.
2. The NEC section 690.43 states, "Exposed non-current carrying metal parts of module frames, equipment, and conductor enclosures shall be grounded in accordance with 250.134 or 250.136(A) regardless of voltage."
3. WEEBs are intended for **SINGLE USE ONLY**. Functionality will not be guaranteed if reused.

# WEEB-DPF ASSEMBLY

1

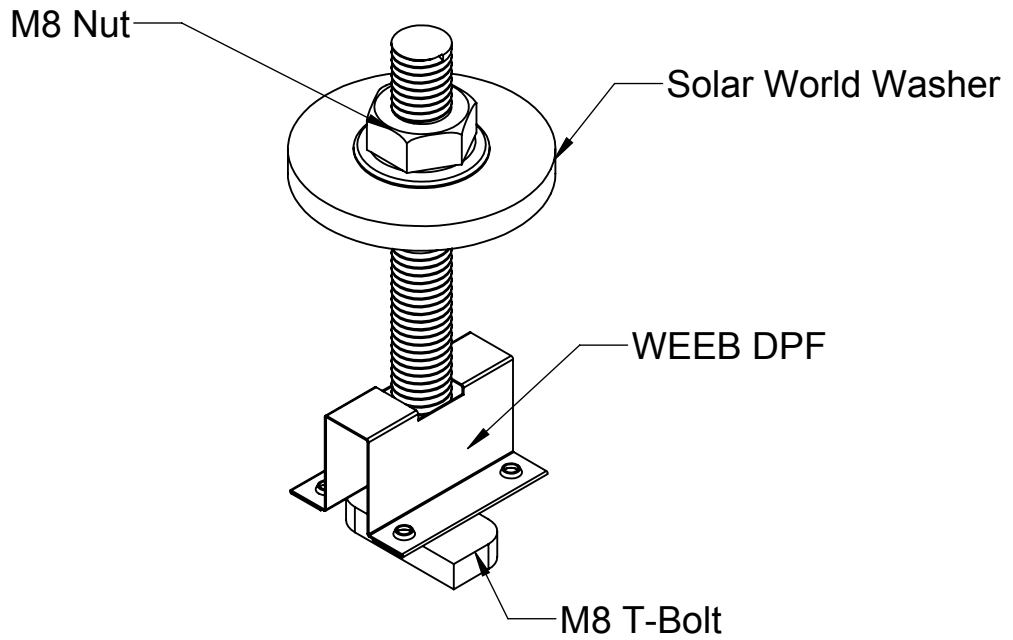

Pre-assemble WEEB-DPF to mid-clamp assembly as shown. Pre-assembling WEEB-DPF to mid-clamp assembly will contain the small individual parts, reducing the possibility of losing parts during installation.

2

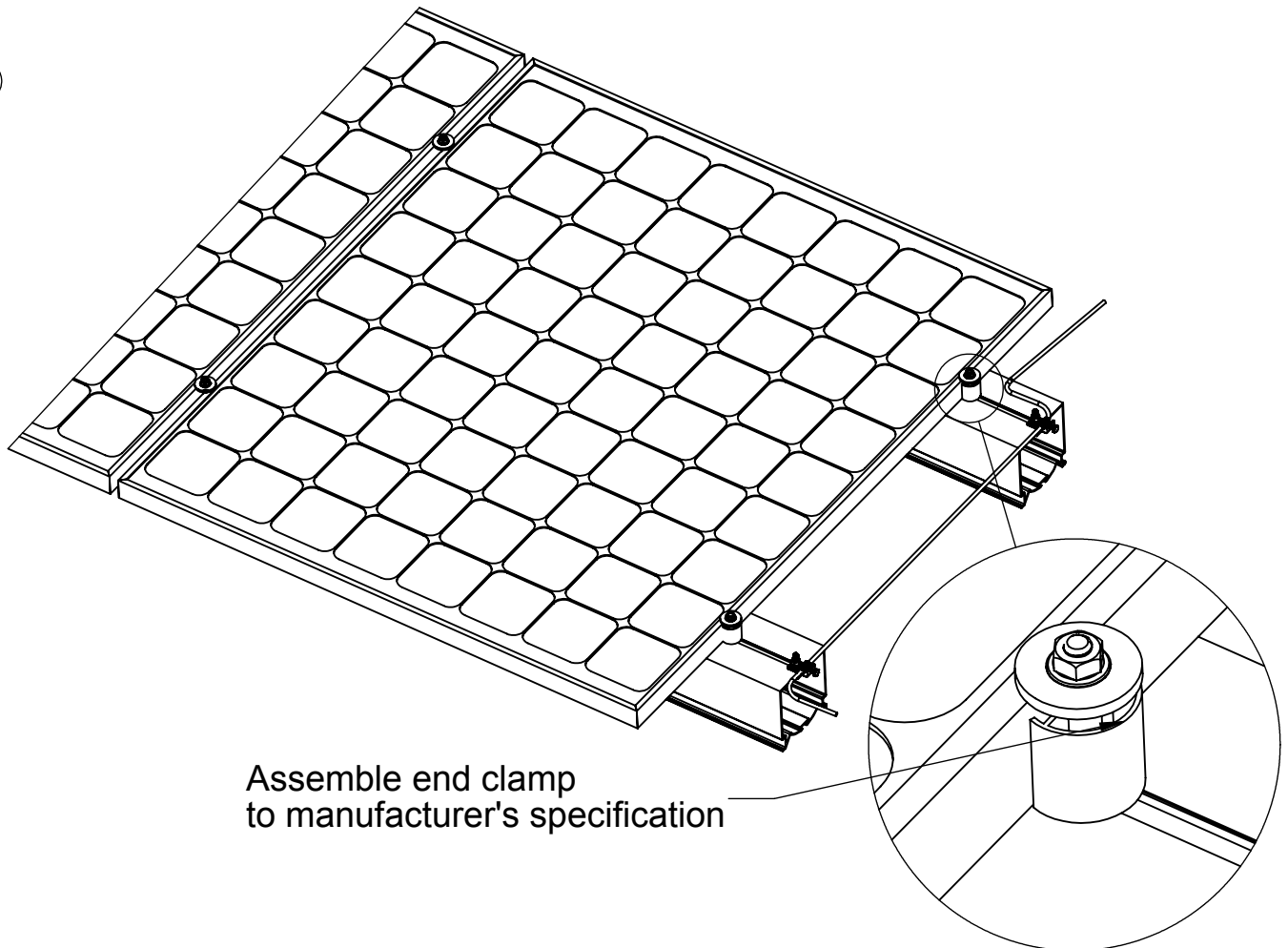

- ③ Slide pre-assembled WEEB-DPF and mid-clamp assembly into position.

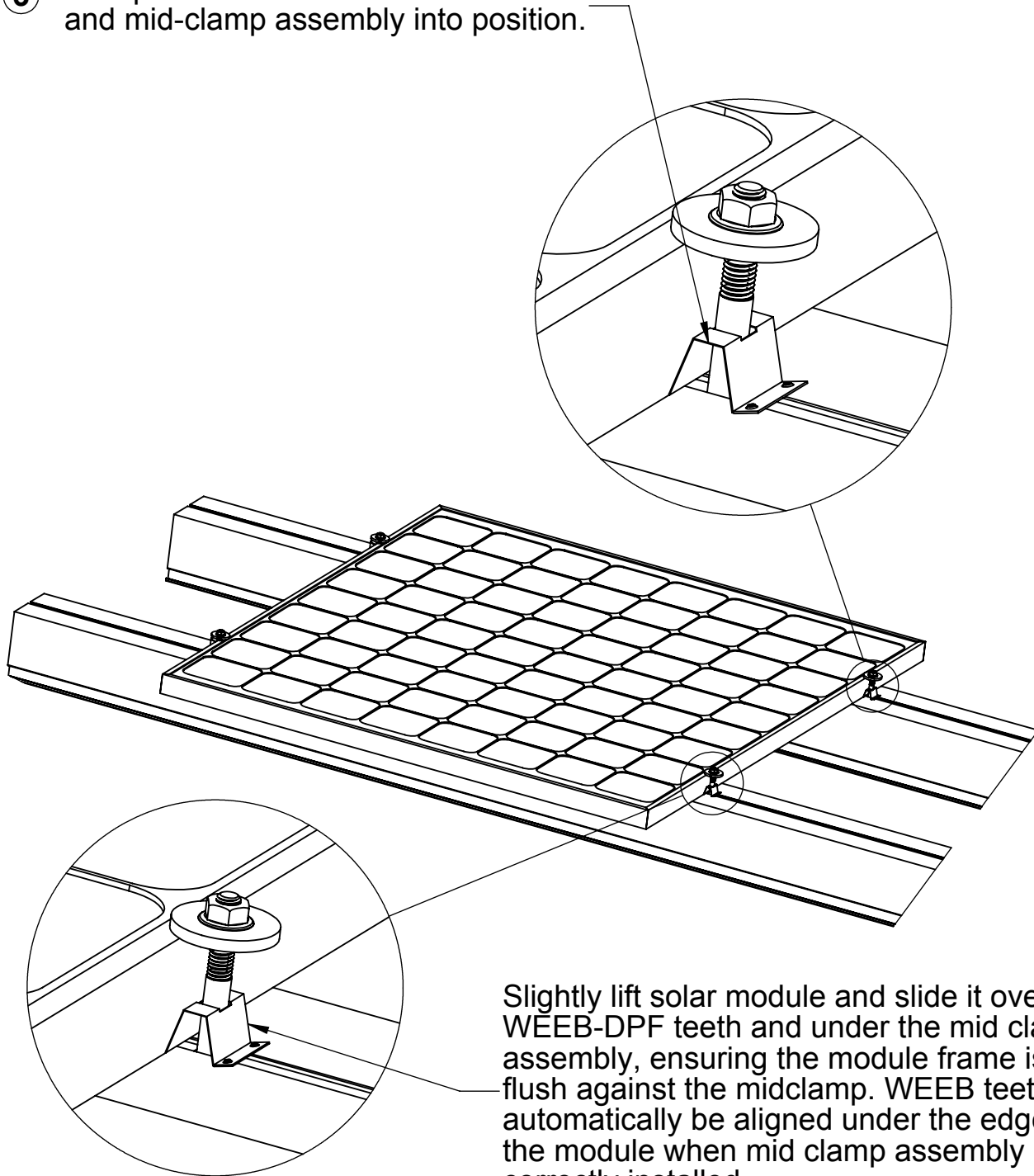

### Important note:

To correctly install WEEB-DPF, ensure that both sides of the solar modules are completely positioned against the mid-clamp. Refer to WEEB compatibility page for illustrations. Visually check that WEEBs are properly positioned.

## Important note:

**WEEBs are for SINGLE USE ONLY! Do not torque fasteners down if position of solar modules is not finalized. Only slightly tighten fasteners to keep modules in place.**

④

When position of solar modules are finalized, torque fasteners to 12ft-lb / 16.3 N-m using general purpose anti-seize compound on threads.

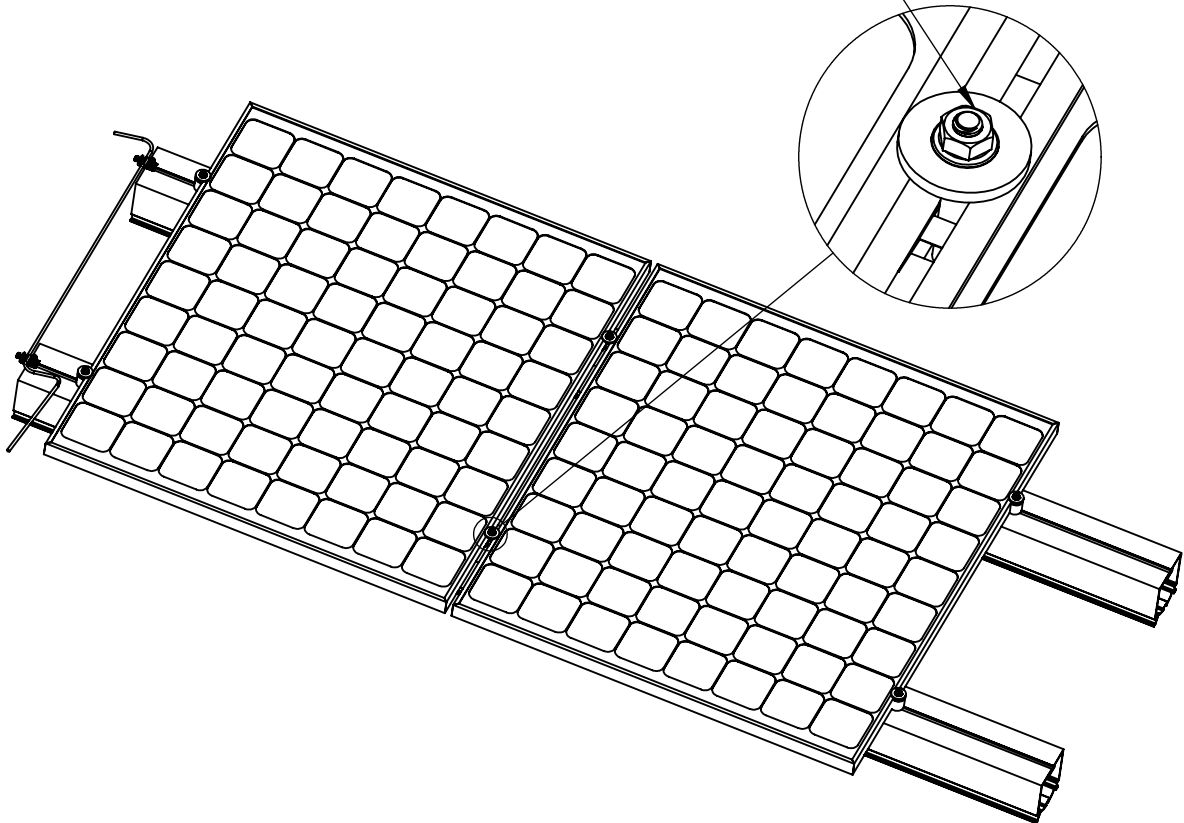

⑤

Assemble end clamp to manufacturer's specification.

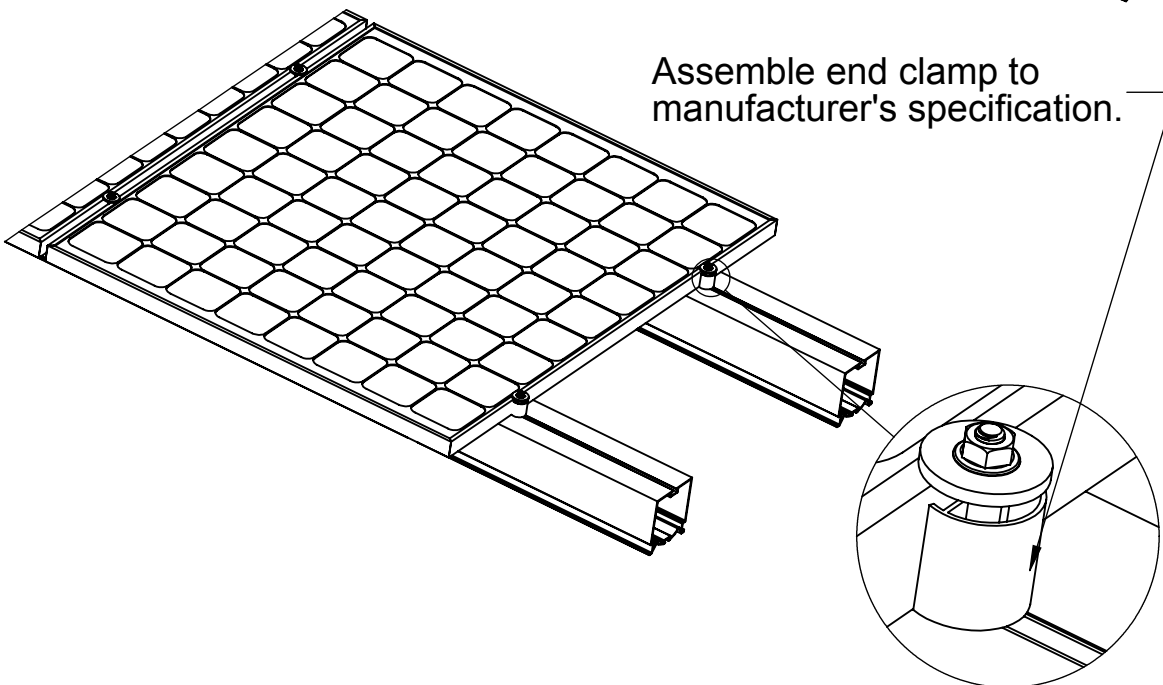

# WEEB-DPF LAYOUT

6

## EVEN NUMBER OF MODULES IN ROW

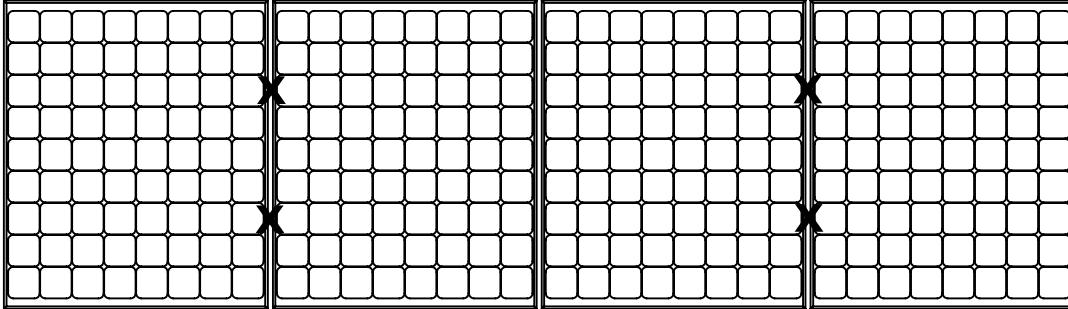

X DENOTES PLACES TO INSTALL WEEB-DPF

$$C \times R = 4 \times 1$$

$$\text{WEEB-DPF NEEDED} = C \times R = 4 \times 1 = 4$$

## ODD NUMBER OF MODULES IN ROW

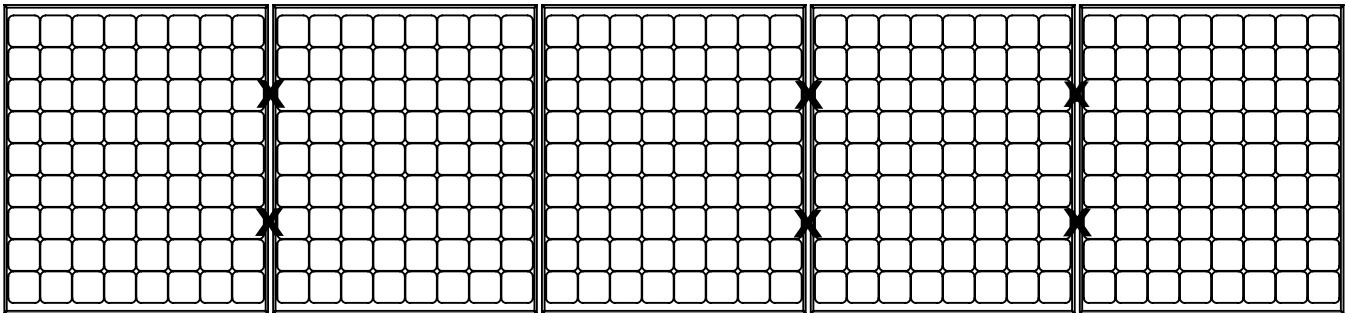

X DENOTES PLACES TO INSTALL WEEB-DPF

$$C \times R = 5 \times 1$$

$$\text{WEEB-DPF NEEDED} = [C+1] \times R = [5+1] \times 1 = 6$$

### Note:

When replacing a single faulty module, also remove the adjacent module which contacts the same WEEBs as the faulty module. This will ensure that there are never ungrounded modules in the array.

# WEEBLUG ASSEMBLY

7

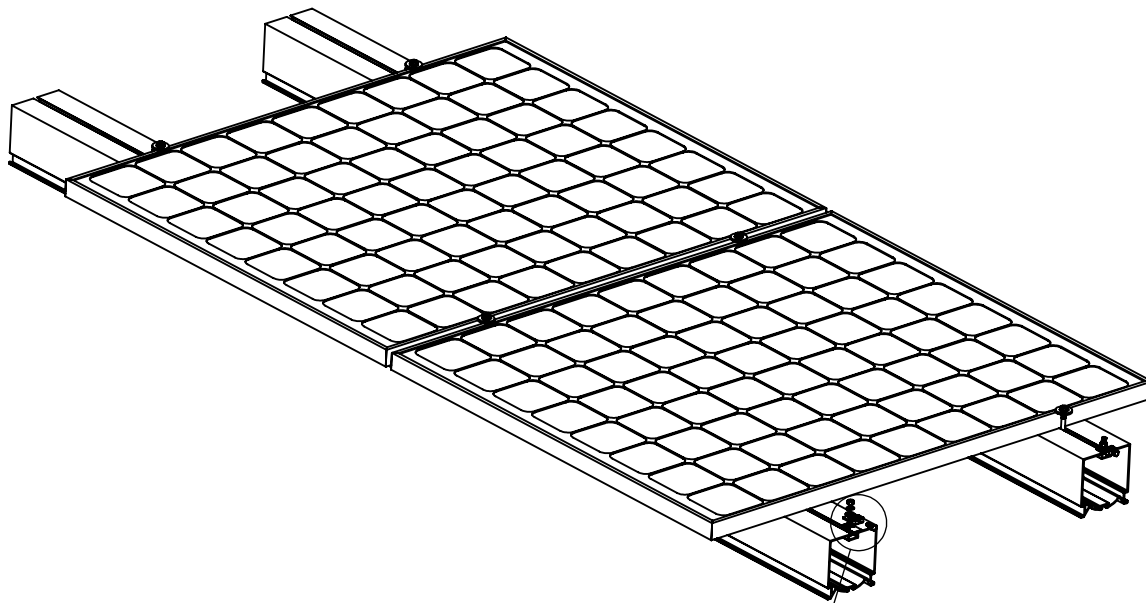

WEEB teeth towards rail

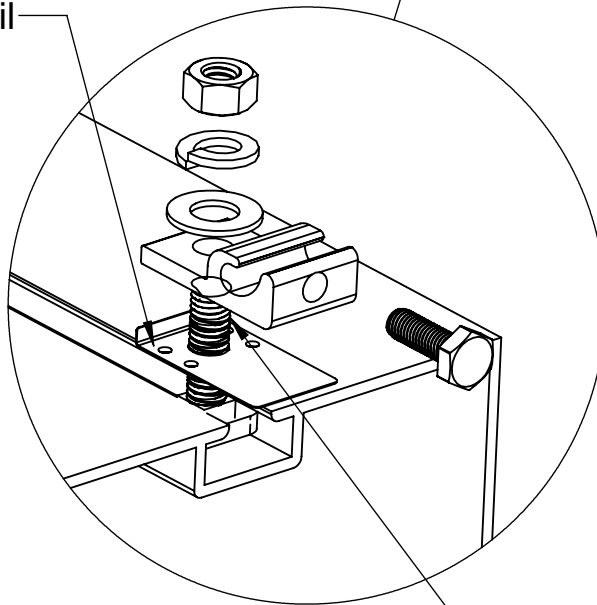

Assemble WEEBLug-8.0 assembly and torque fasteners to 10 ft-lb / 13.5 N-m using general purpose anti-seize compound on threads.

## Important note:

1. **WEEB-8.0 that sits under the WEEBLug is for SINGLE USE ONLY! Ensure position is correct before tightening.**
2. **The WEEBLug-8.0 may be used with a maximum equipment ground wire of 6 AWG.**

# GROUND CONDUCTOR ASSEMBLY

8

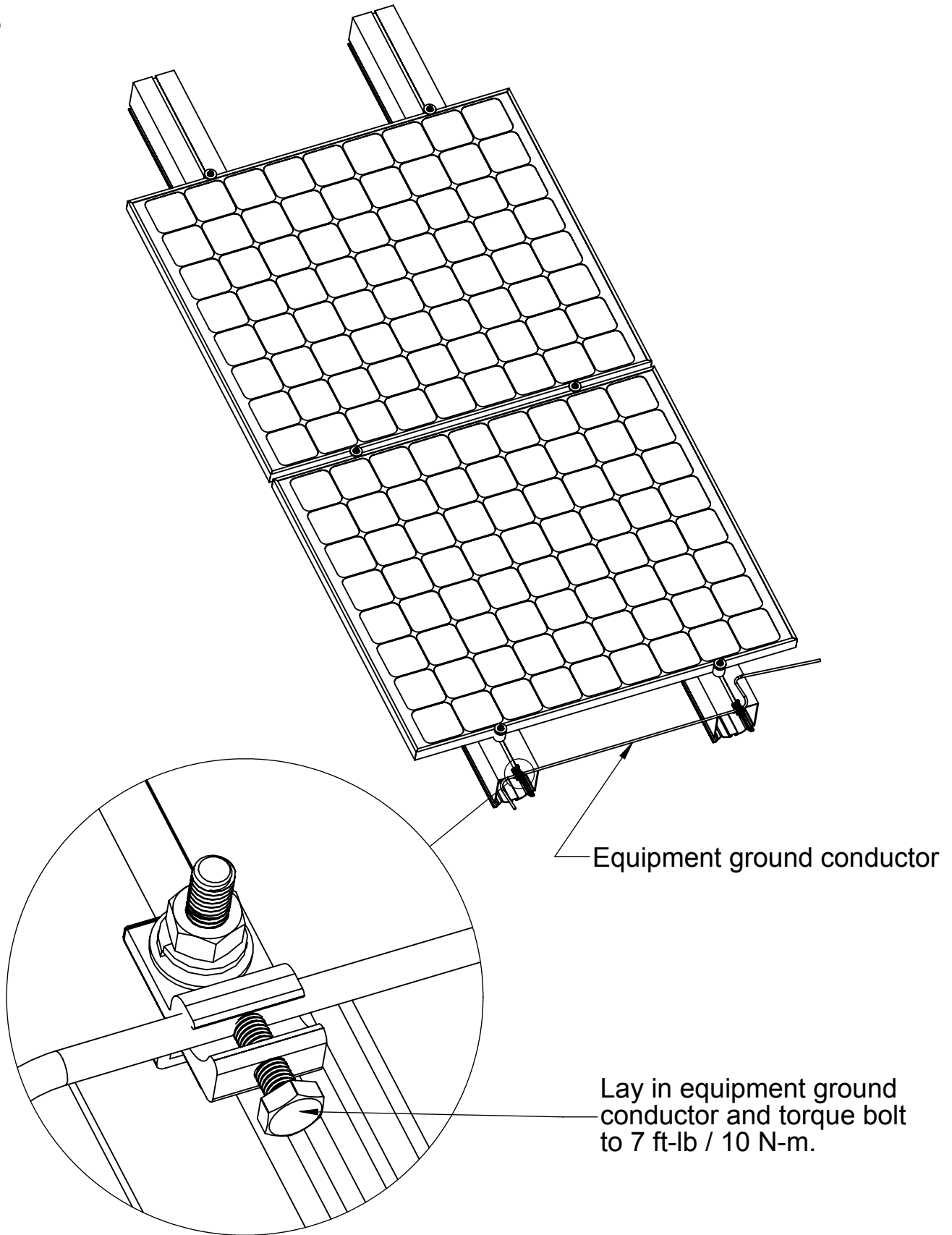

# SOLAR WORLD SPLICE KIT ASSEMBLY

9

WEEB Bonding Jumper can be used for all rail splices including expansion joints.

