

Wiley Electronics LLC Washer, Electrical Equipment Bonding and Lug (WEEBLug)

The WEEBLug is a new patent pending device for bonding a solar array. The WEEBLug consists of two parts. The washer portion is designed to provide a reliable electrical connection with anodized aluminum pieces. The lug portion allows the lay-in connection of an electrical equipment grounding conductor. The WEEBLug may be attached to the top of a mounting rail with a captive bolt, or fastened to any aluminum piece after drilling a ¼ inch clearance hole.

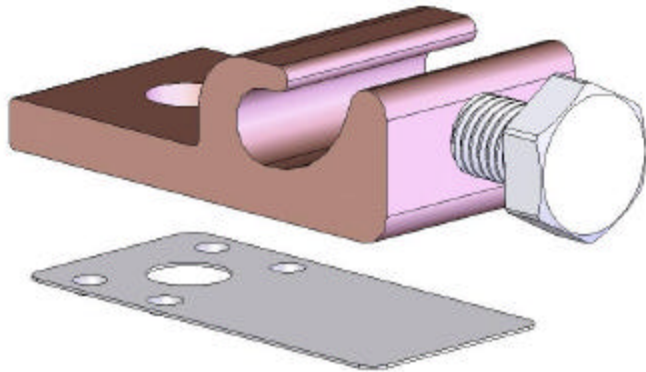

Figure 1. WEEBLug

Usage: Insert a bolt in the aluminum rail or through the clearance hole in the aluminum piece. Place the washer portion on the bolt, oriented so that the dimples will contact the aluminum piece. Place the lug portion on the bolt and washer portion. Install stainless steel washer and nut. Tighten the nut until the dimples are completely embedded and the lug and aluminum piece are flat against the body of the WEEB. The embedded dimples will make a gas-tight mechanical connection and thus ensure good electrical connection between the aluminum and the lug.

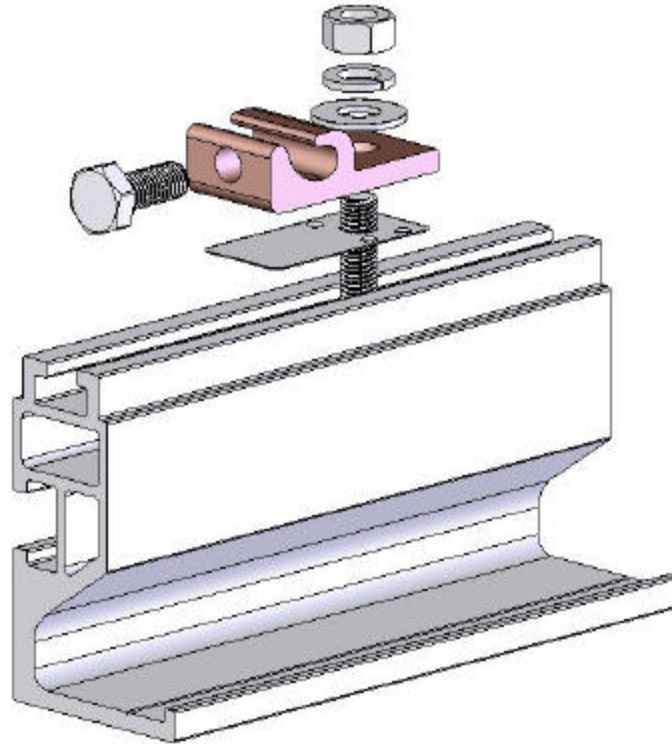

Figure 2. WEEBLug mounted on rail.

material: washer - 304 stainless steel
lug – tin plated copper

UL467 listed
maximum wire size: 6 AWG

outdoor rated

part number:
WEEBL-6.7 for use with ¼ inch mounting hardware
WEEBL-8.0 for use with 5/16 inch mounting hardware
WEEBL-8.2 for use with 8 mm mounting hardware