



## Washer, Electrical Equipment Bond

# WEEB

Patent Pending

## INSTALLATION INSTRUCTIONS

# *For Würth Canada Mounting System only*

**Please read carefully before installing.**

Burndy LLC. recommends that the sufficient details of the installation be submitted to the AHJ for approval before any work is started.

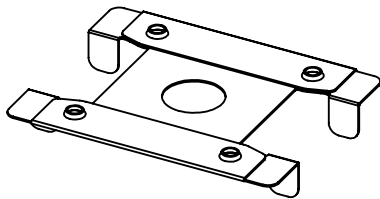

WEEB-CCR

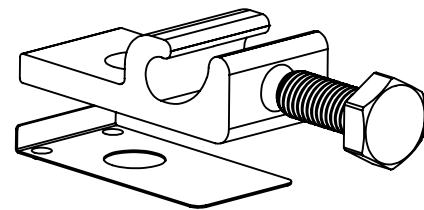

WEEBLug-15.8



Products are tested to UL 467, CAN/CSA-C22.2 No. 41  
US/Canadian standards for safety grounding and bonding equipment



# WEEB COMPATIBILITY

The WEEB family of products can be used to bond anodized aluminum, galvanized steel, steel and other electrically conductive metal structures. All installations shall be in accordance with NEC requirements in the USA and with CSA C22.1 in Canada. The WEEBs are for use with modules that have a maximum series fuse rating of less than 25A.

## Standard Top Down Clamps

The WEEBs used for bonding the PV modules to the mounting rails are compatible with various cross-sections of module frames. The following are examples of module frames that are compatible. Notice that the WEEB teeth are positioned completely under the edge of the module frame.

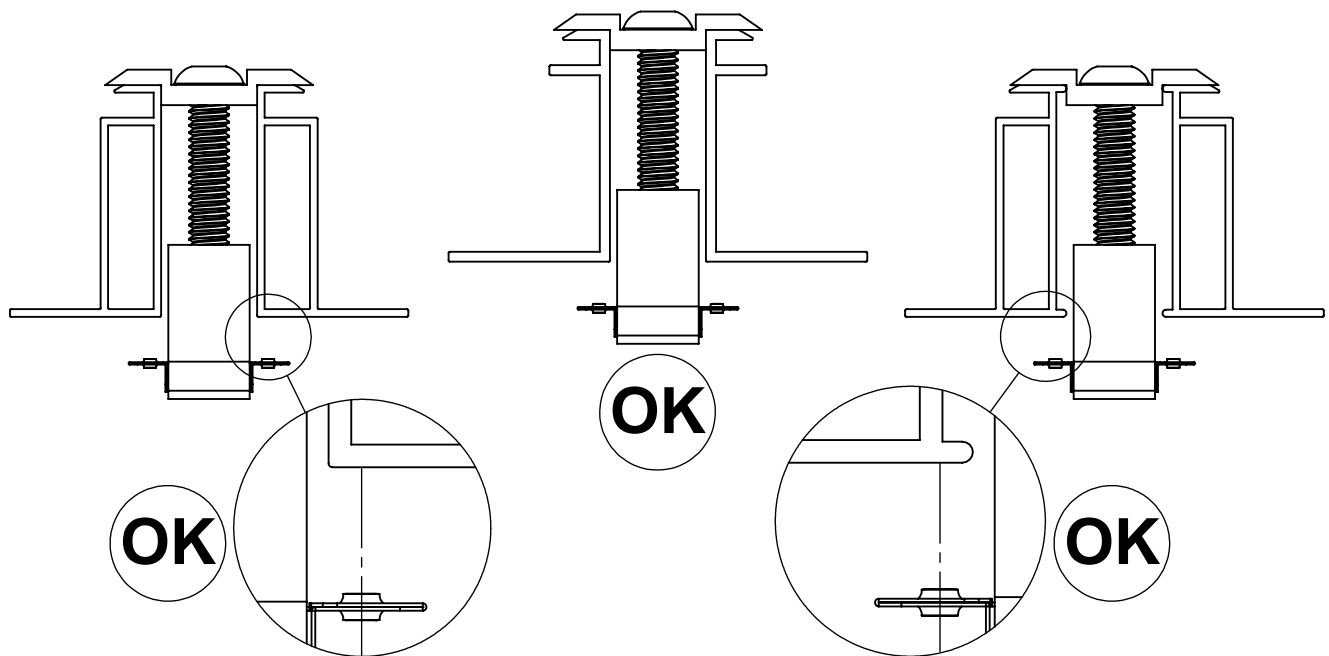

The following is an example of a module frame that is incompatible with the WEEB. The upper lip of the module frame locates the frame against the midclamp so that the WEEB teeth do not fall under the frame at the correct location. This will cause an improper embedding.

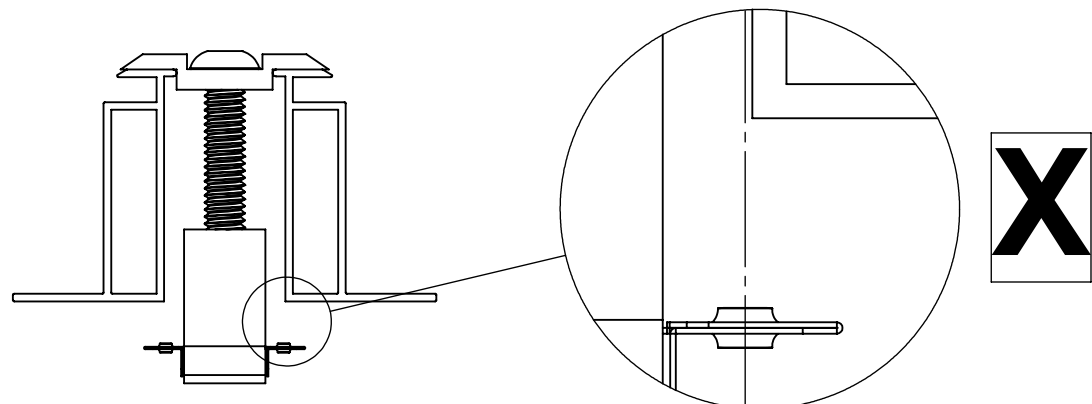

# WEEB COMPATIBILITY

Module frames like those shown here may have a ridge or lip on the bottom edge of the frame that would prevent the WEEB teeth from fully embedding.

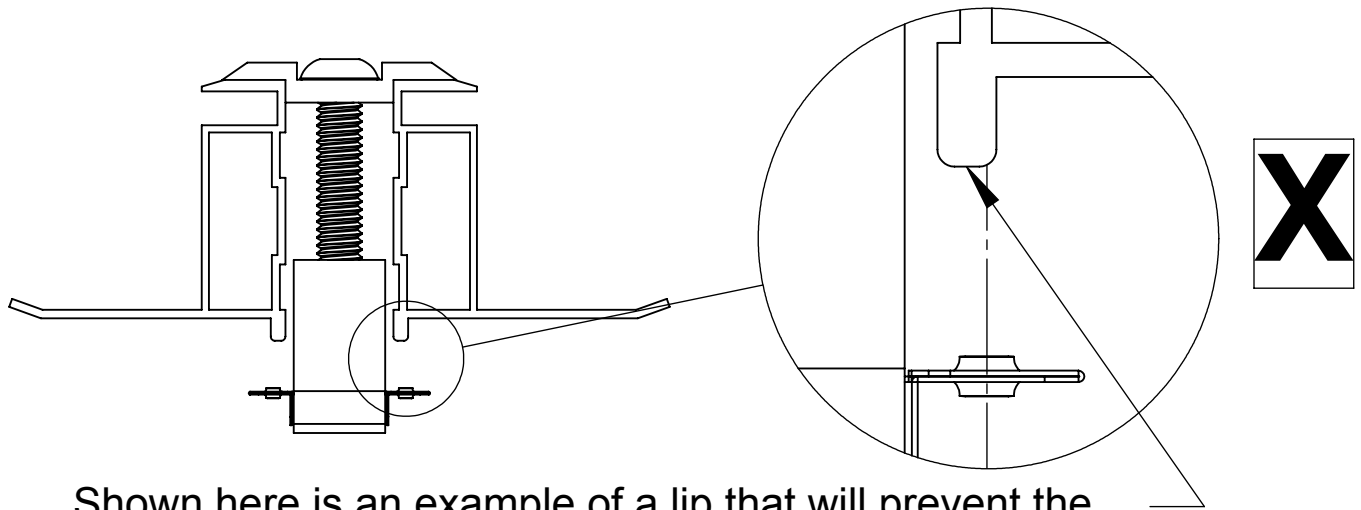

Shown here is an example of a lip that will prevent the WEEB teeth from properly penetrating the module frame. This type of frame is not compatible with the WEEB.

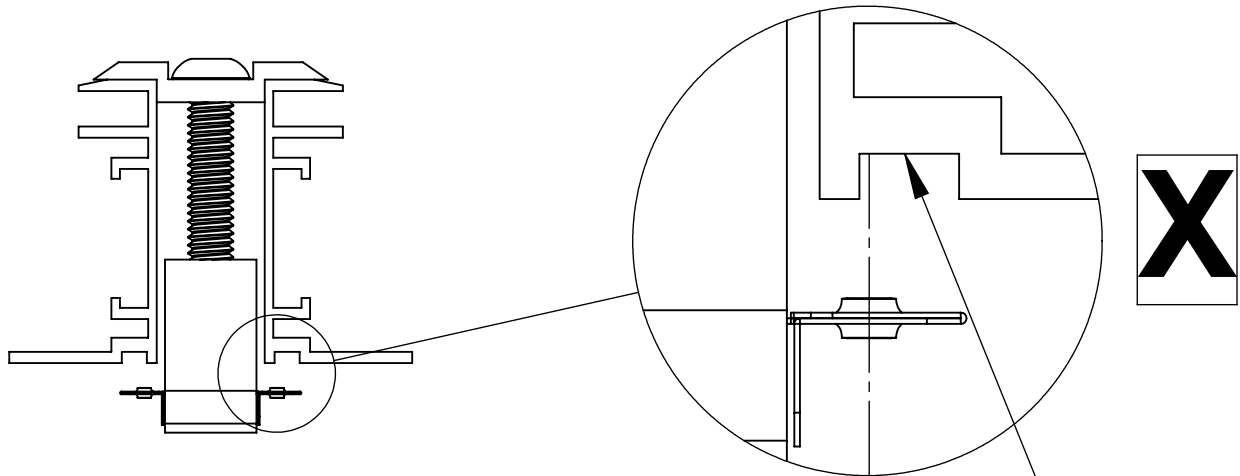

Shown here is an example of a groove that will prevent the WEEB teeth from properly penetrating the module frame. This type of frame is not compatible with the WEEB.

## Important Note:

**Inspect each module frame used with a WEEB to ensure that the bottom mounting face of the frame is flat, and that there are no hinderances to embedding WEEB teeth. Do not use a module with a frame that prevents the WEEB teeth from embedding fully.**

# WEEB-CCR on Boxed Module Frames

Certain module frames do not have enough structural strength to withstand the force required to embed a WEEB. These frames will deform and therefore not allow sufficient penetration of the WEEB teeth. The general requirements for minimum module frame thickness of "boxed" type module frames are illustrated below.

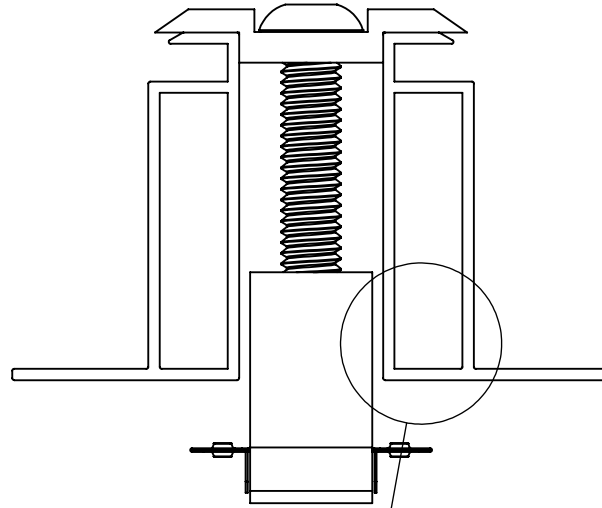

NO LESS THAN 3.0mm  
NO GREATER THAN 8.5mm

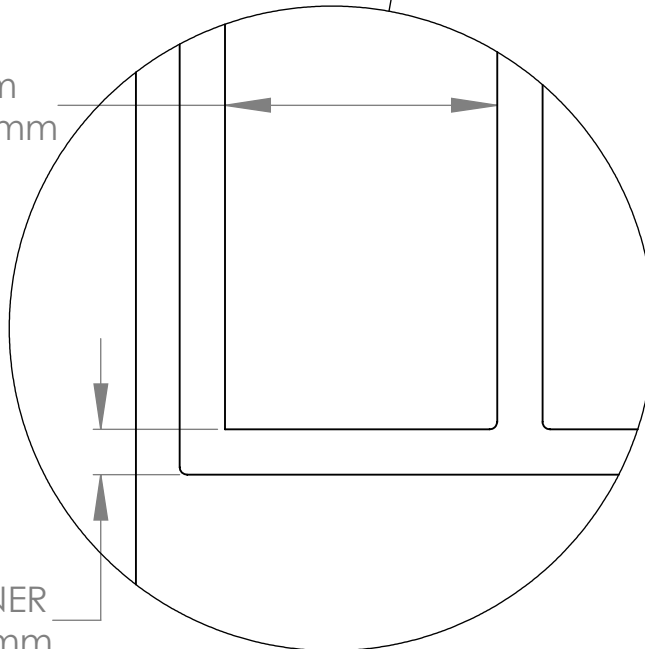

NO THINNER  
THAN 1.5mm



# SYSTEM OVERVIEW

Use WEEB-CCR to bond solar modules to module mounting rail.

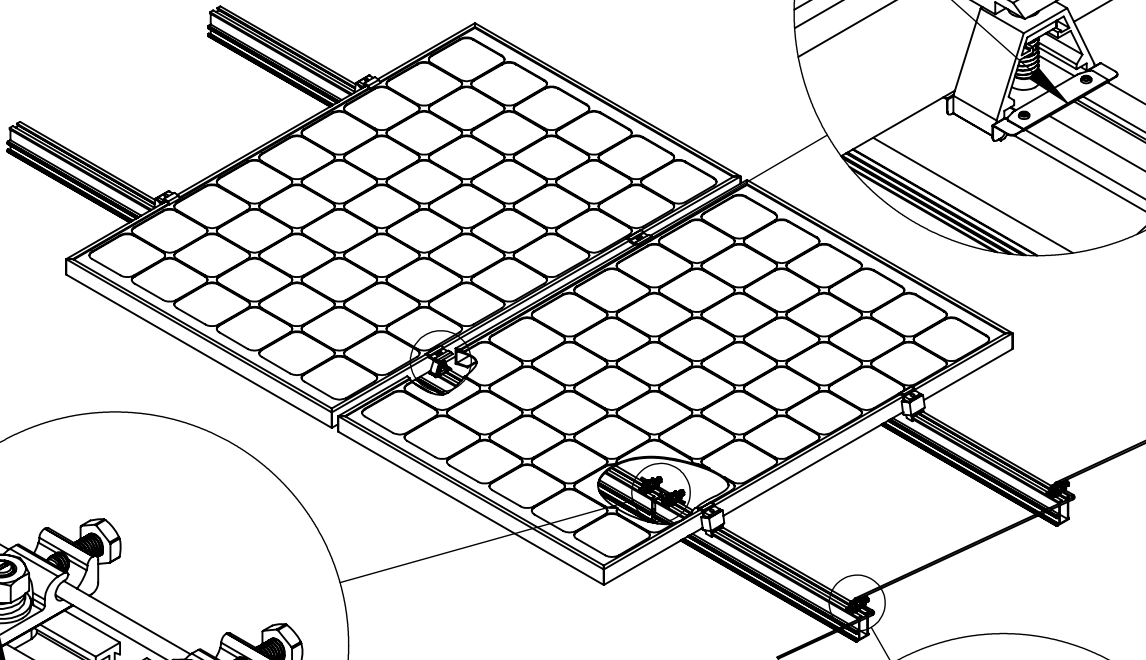
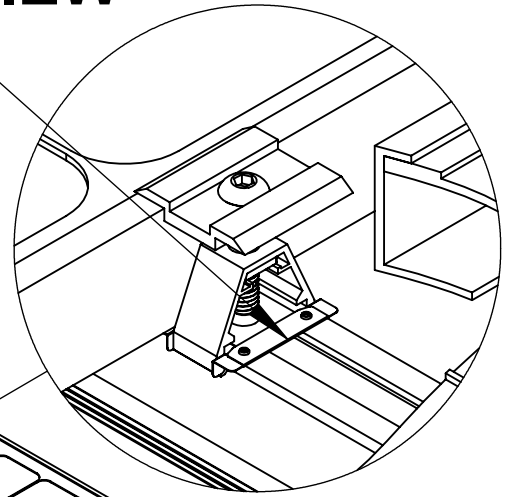

Use two (2) WEEBLug-15.8's to electrically connect mechanically spliced rails.

Use one WEEBLug-15.8 assembly per rail to connect system to equipment ground conductor.

## Important notes

1. Use general purpose anti-seize compound on fastener threads when installing WEEBs.
2. The NEC section 690.43 states, "Exposed non-current carrying metal parts of module frames, equipment, and conductor enclosures shall be grounded in accordance with 250.134 or 250.136(A) regardless of voltage."
3. WEEBs are intended for **SINGLE USE ONLY**. Functionality will not be guaranteed if reused.

# MID-CLAMP AK HD ASSEMBLY UTILIZING WEEB-CCR

①

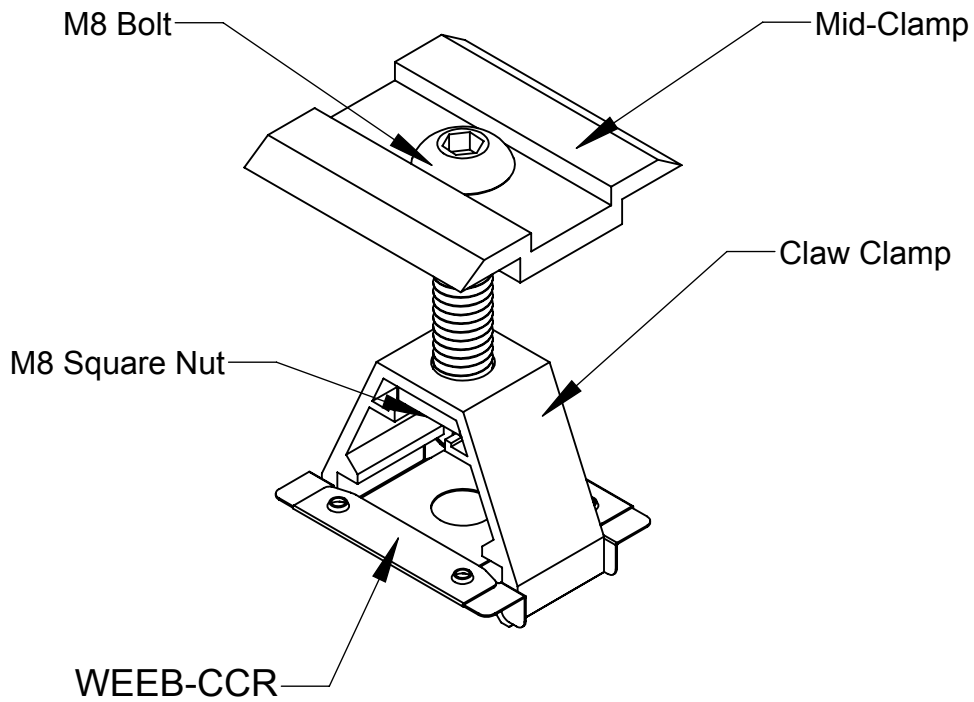

②

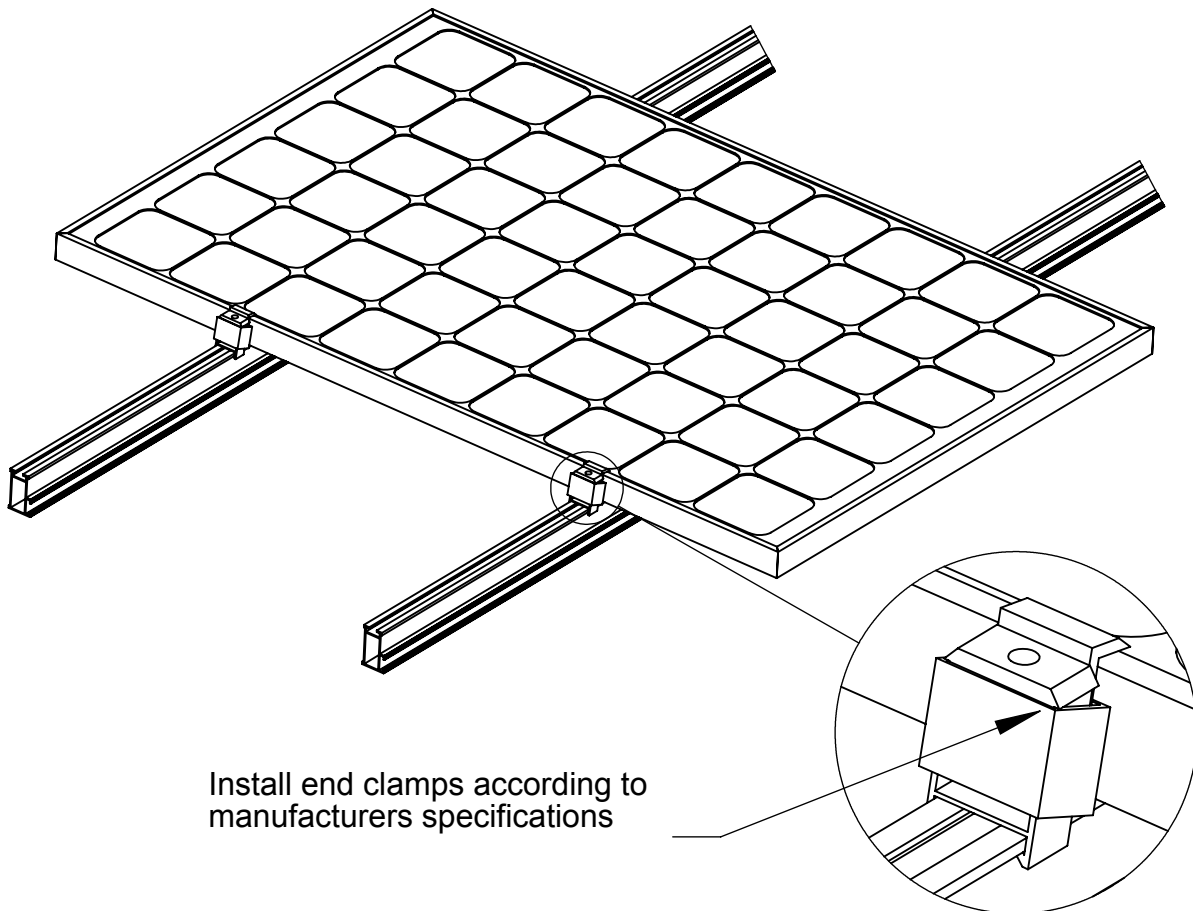

# WEEB-CCR ASSEMBLY

3

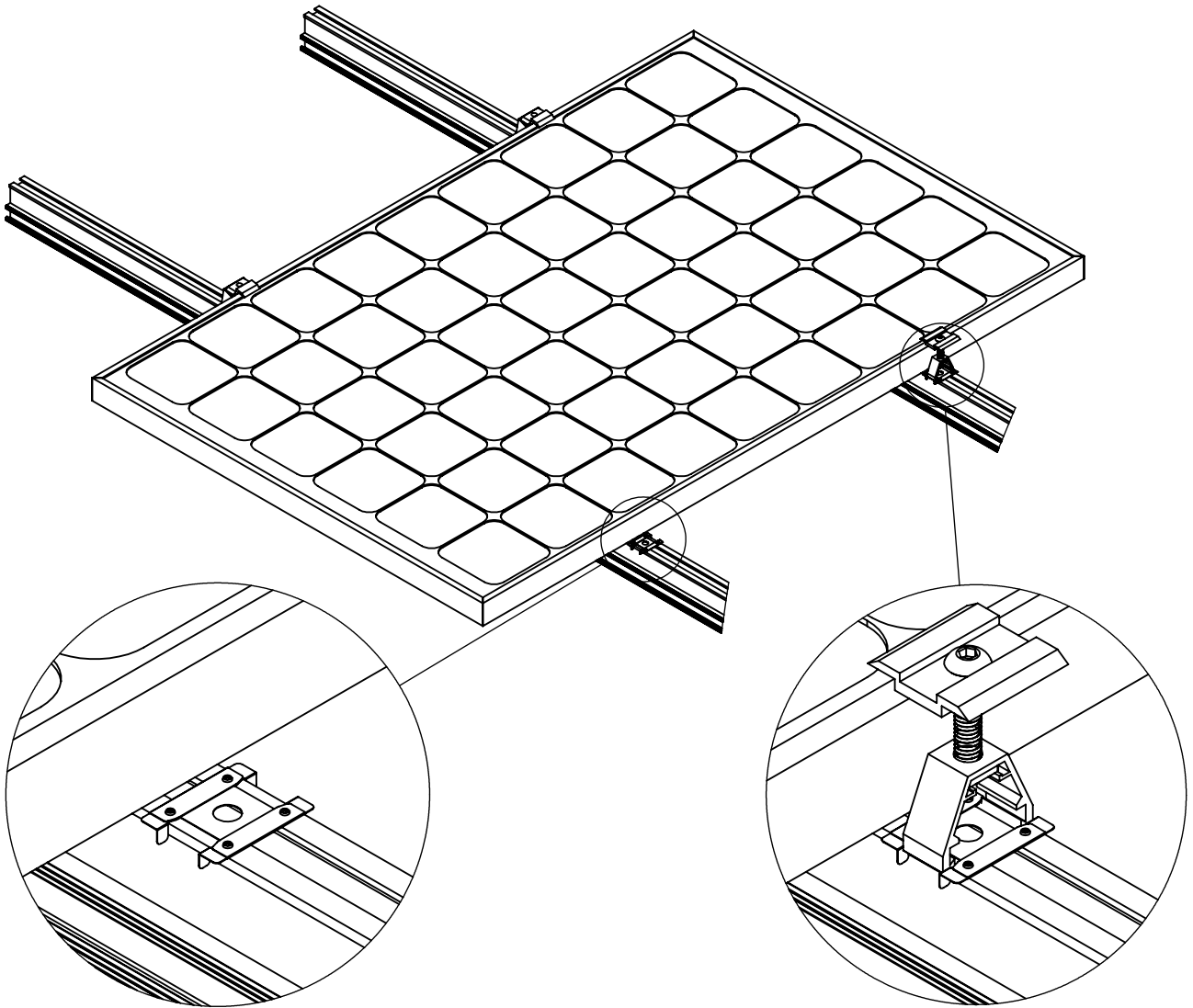

Place a WEEB-CCR on the Würth Canada Rail with the tabs down engaging the rail

Take a Mid-Clamp AK HD Assembly and clip it onto the rail over the WEEB-CCR

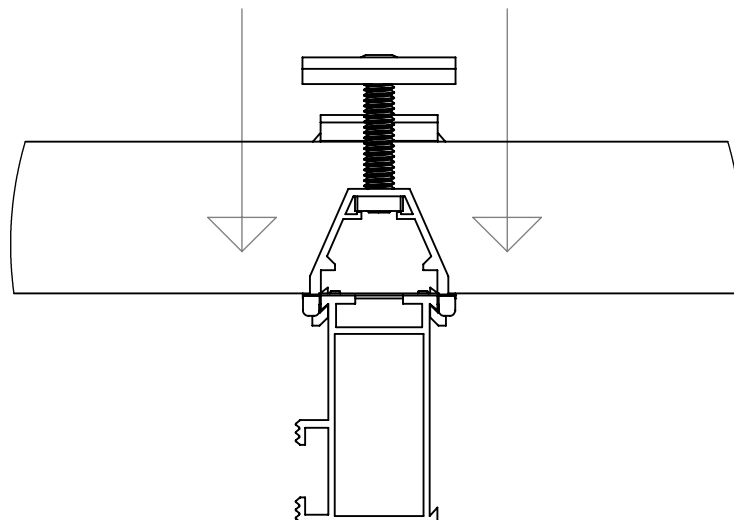

③ continued

Install WEEB-CCR and mid clamp assembly in position. Do not tighten hardware yet.

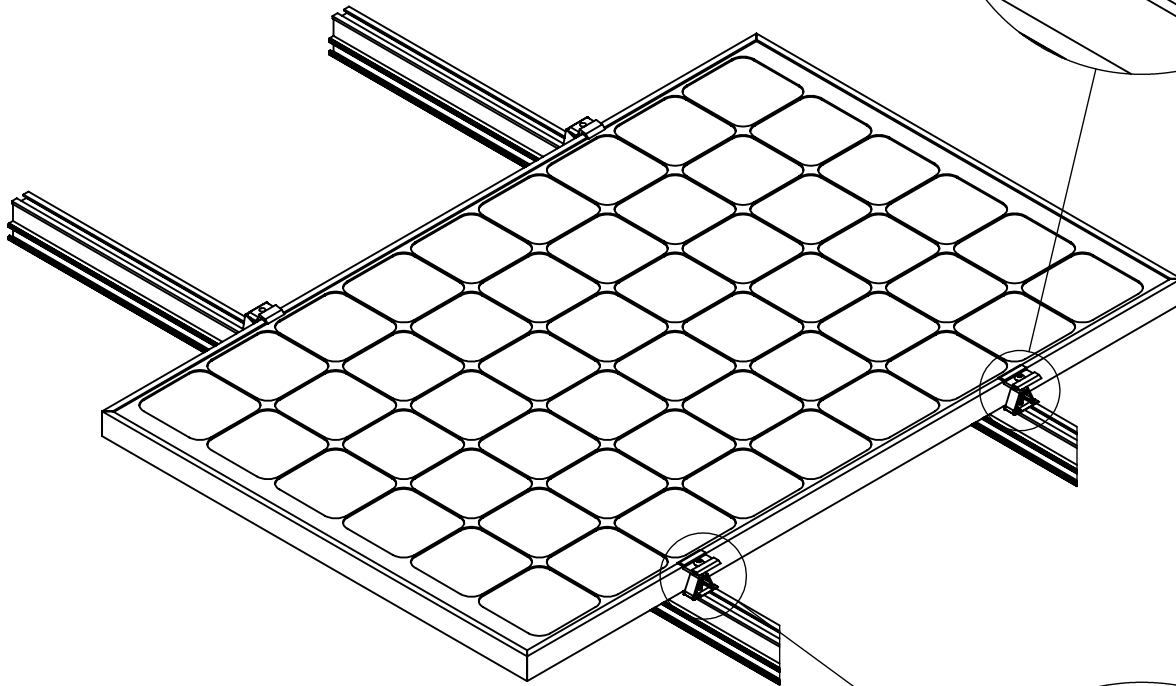

Slightly lift solar module and slide it over the WEEB-CCR teeth and under the mid clamp assembly, ensuring the module frame is flush against the mid clamp.

WEEB teeth will automatically be aligned under the edge of the module when mid clamp assembly is correctly installed.

### **Important note:**

**To correctly install mid clamp assembly, ensure that the bolt is perpendicular to the mounting rail and both sides of the solar modules are completely positioned against the mid clamp. Refer to WEEB compatibility page for illustrations. Visually check that WEEBs are properly positioned.**

## Important note:

**WEEBs are for SINGLE USE ONLY! Do not torque fasteners down if position of solar modules is not finalized. Only slightly tighten fasteners to keep modules in place.**

- ④ When position of solar modules is finalized, **torque M8 fasteners to 12 ft-lb / 16.3 N-m** using general purpose anti-seize compound on threads.

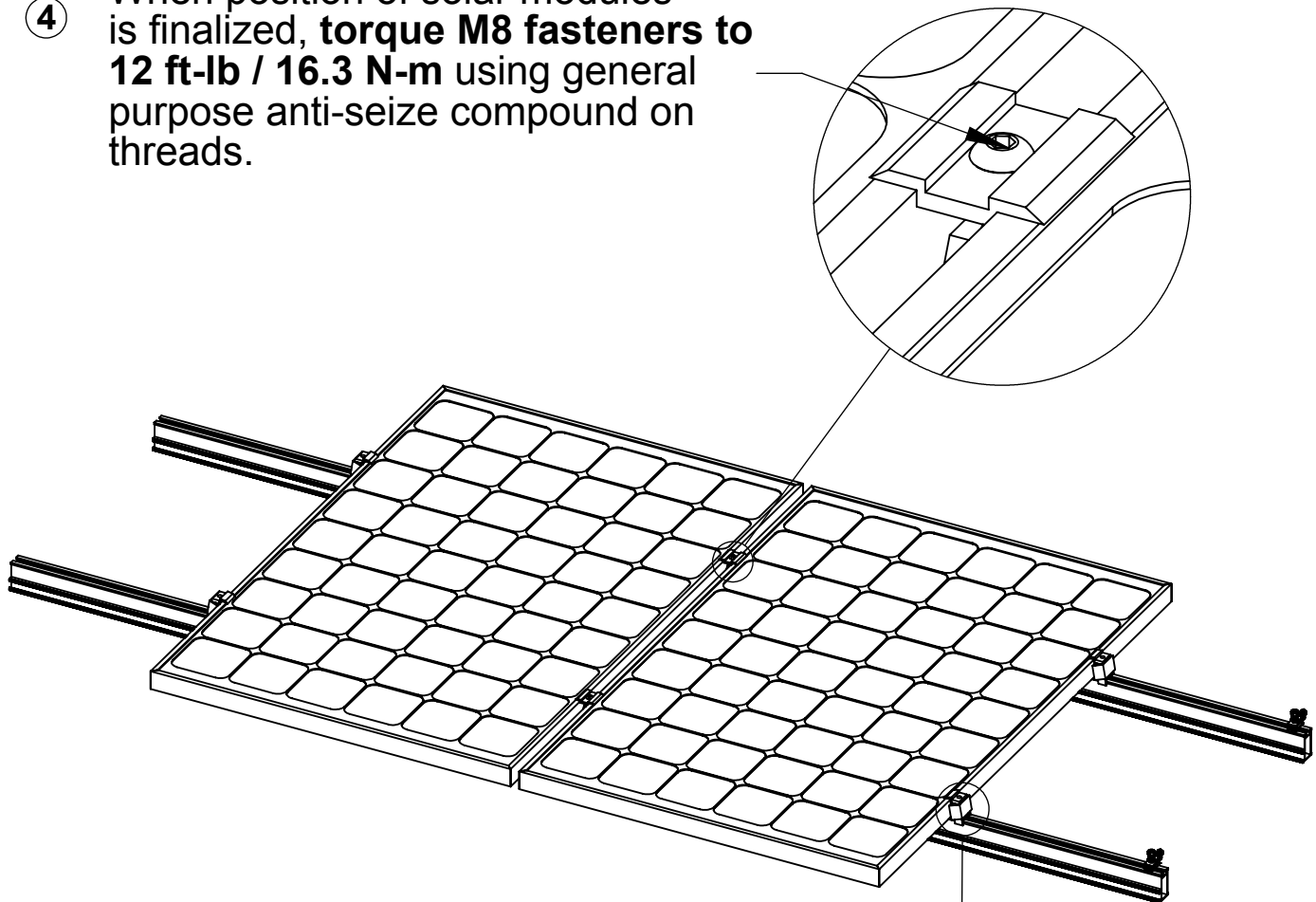

- ⑤ Assemble end clamp to manufacturer's specification.

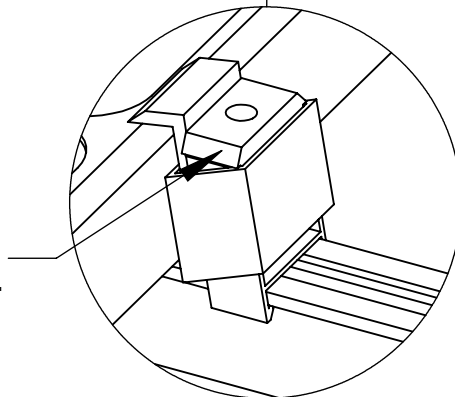

6

# WEEB-CCR LAYOUT

## EVEN NUMBER OF MODULES IN ROW

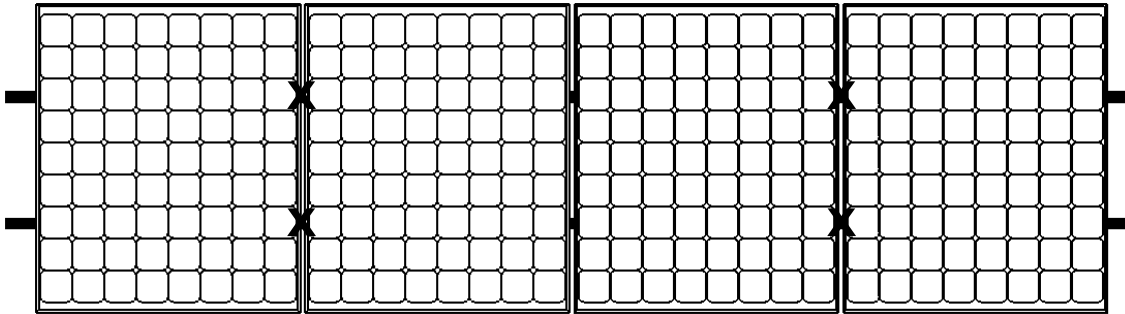

X DENOTES PLACES TO INSTALL WEEB-CCR

$$C \times R = 4 \times 1$$

$$\text{WEEB-CCR NEEDED} = C \times R = 4 \times 1 = 4$$

## ODD NUMBER OF MODULES IN ROW

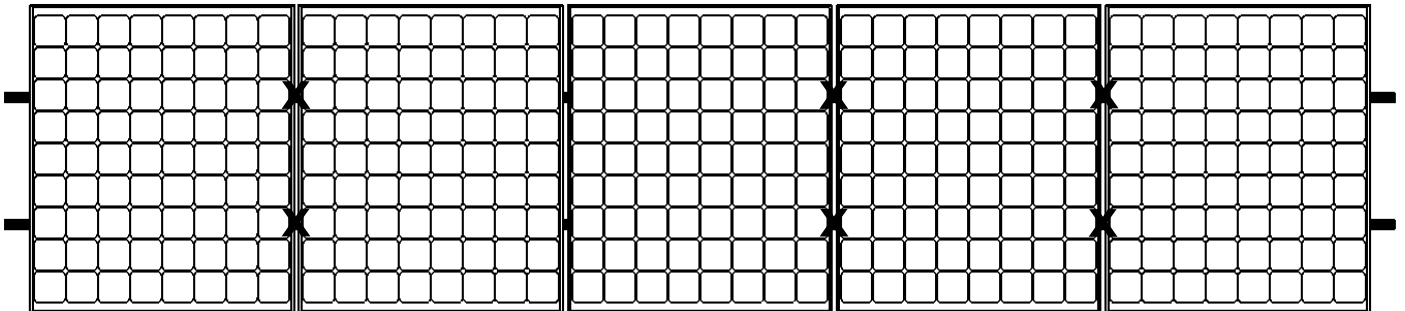

X DENOTES PLACES TO INSTALL WEEB-CCR

$$C \times R = 5 \times 1$$

$$\text{WEEB-CCR NEEDED} = [C+1] \times R = [5+1] \times 1 = 6$$

### Note:

When replacing a single faulty module, also remove the adjacent module which contacts the same WEEBs as the faulty module. This will ensure that there are never ungrounded modules in the array.

# WEEBLUG ASSEMBLY

7

M8 Nut  
M8 Split Lock Washer  
M8 Flat Washer

Install M8 T-bolt at desired position and slip WEEB-15.8 over the bolt

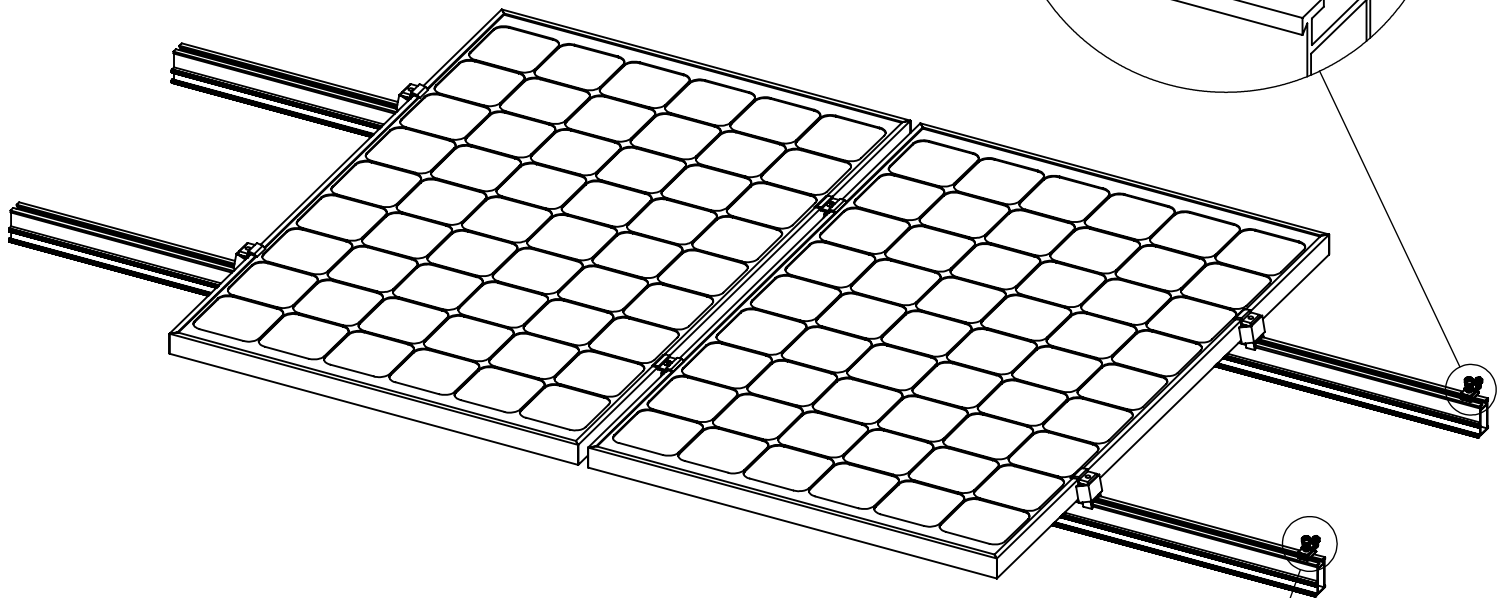

Install WEEBLug-15.8 assembly and **torque M8 T-Bolt fasteners to 12 ft-lb / 16.3 N-m** using general purpose anti-seize compound on threads.

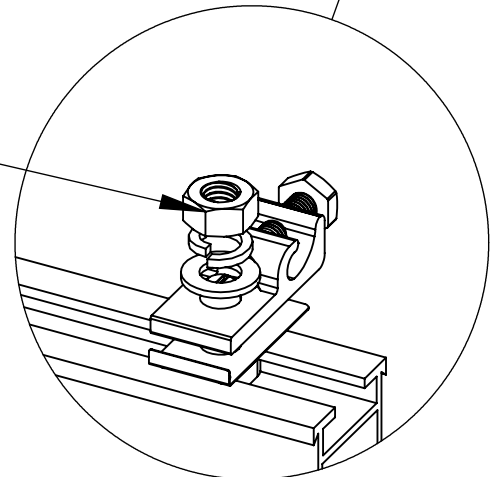

## Important note:

1. WEEB-15.8 that sits under the WEEBLug is for **SINGLE USE ONLY**. Ensure position is correct before tightening down.
2. The WEEBLug-15.8 may be used with a maximum equipment ground wire of **6 AWG**.

# GROUND CONDUCTOR ASSEMBLY

8

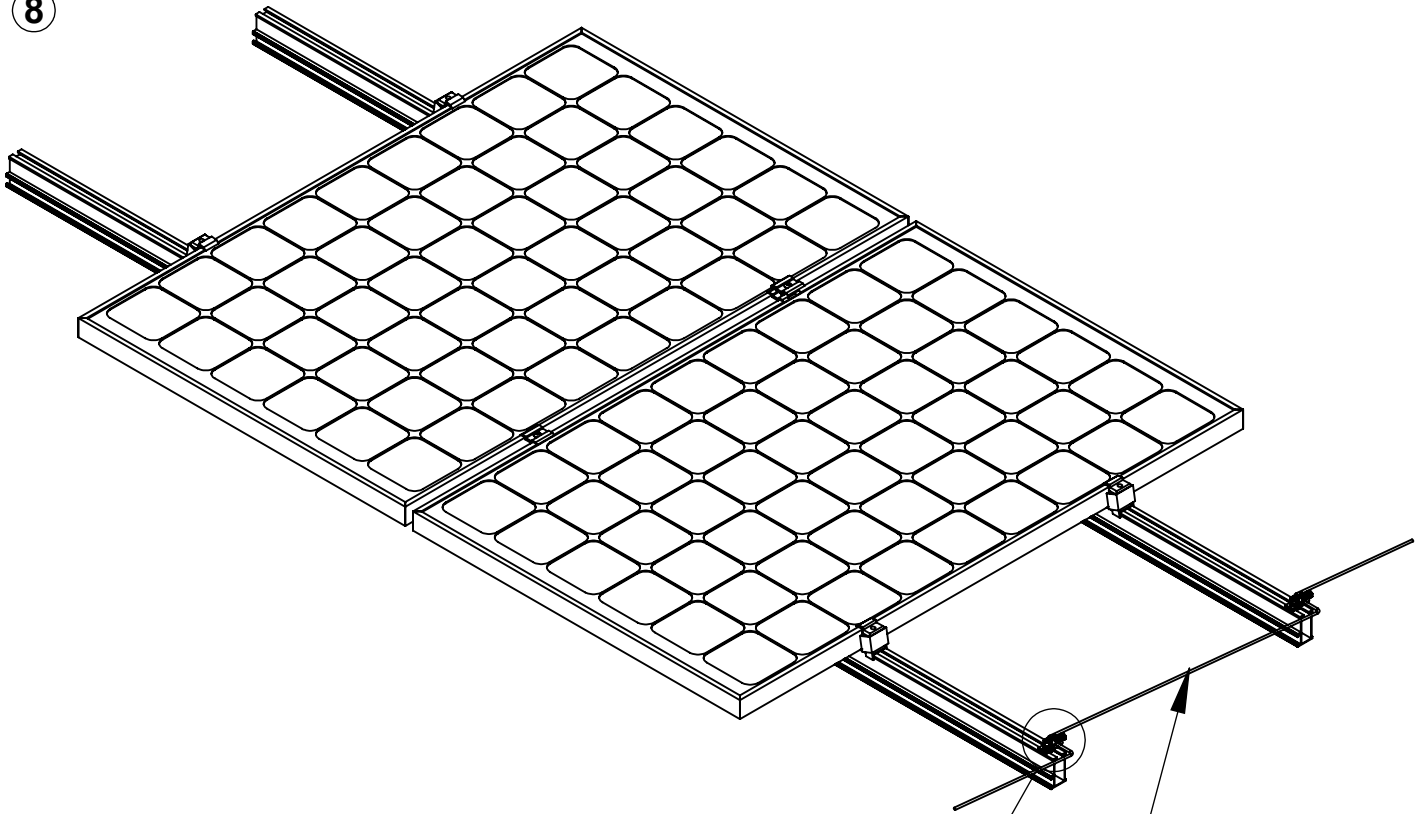

Lay in equipment ground conductor and **torque terminal screw to 7 ft-lb / 10 N-m.**

Equipment  
Ground  
Conductor

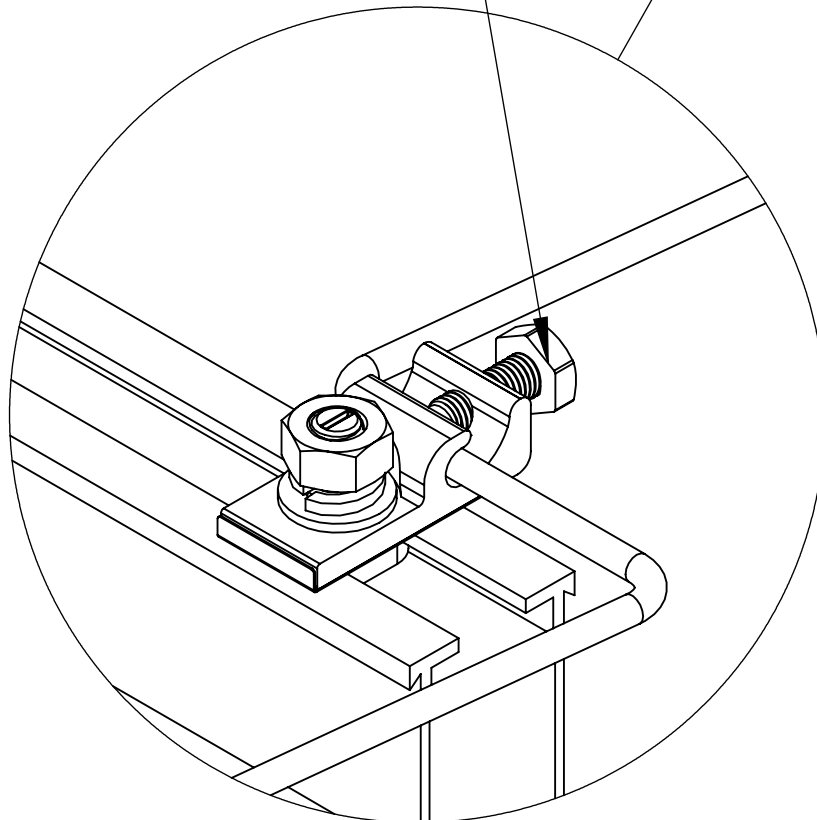

# SPLICE KIT ASSEMBLY

9

Use two (2) WEEBLug-15.8's and a short section of 6 Gauge EGC wire to create a splice

2) Torque M8 T-bolt hardware  
12 ft-lb / 16.3 N-m using general  
purpose anti-seize compound on threads.

4) Tighten the terminal screw  
with 7ft-lbs / 10 N-m of torque

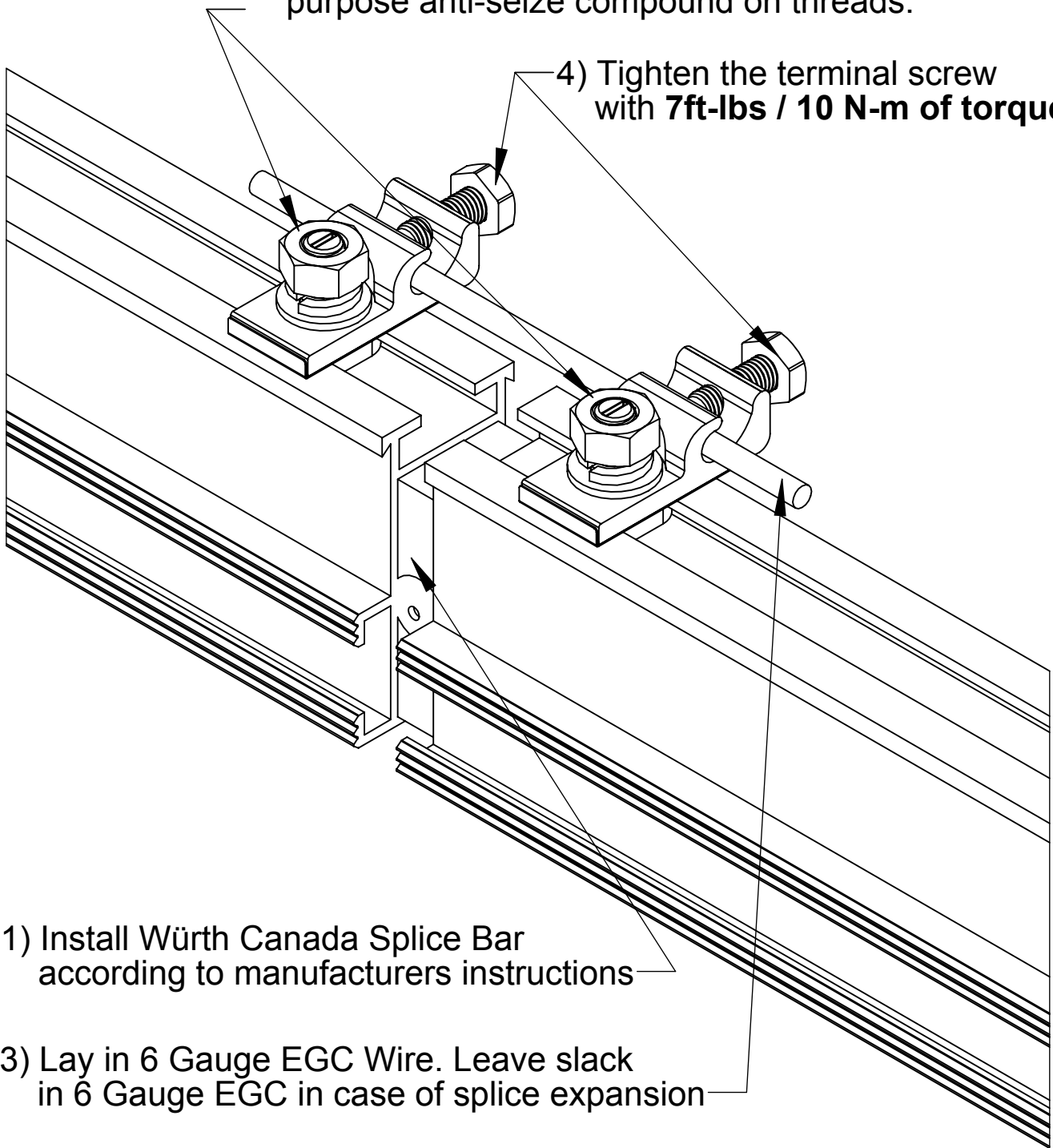

1) Install Würth Canada Splice Bar  
according to manufacturers instructions

3) Lay in 6 Gauge EGC Wire. Leave slack  
in 6 Gauge EGC in case of splice expansion